

#### PROTECTION PRODUCTS - RailClamp®

#### Description

RailClamps® are surge rated diode arrays designed to protect high speed data interfaces. This series has been specifically designed to protect sensitive components which are connected to data and transmission lines from overvoltage caused by **ESD** (electrostatic discharge), **CDE** (Cable Discharge Events), and **EFT** (electrical fast transients).

The unique design incorporates surge rated, low capacitance steering diodes and a TVS diode in a single package. During transient conditions, the steering diodes direct the transient to either the positive side of the power supply line or to ground. The internal TVS diode prevents over-voltage on the power line, protecting any downstream components.

The low capacitance array configuration allows the user to protect four high-speed data or transmission lines. The low inductance construction minimizes voltage overshoot during high current surges. This device is optimized for ESD protection of portable electronics. They may be used to meet the ESD immunity requirements of IEC 61000-4-2, Level 4 ( $\pm 15\text{kV}$  air,  $\pm 8\text{kV}$  contact discharge).

#### Features

- ◆ Transient protection for high-speed data lines to **IEC 61000-4-2 (ESD)  $\pm 15\text{kV}$  (air),  $\pm 8\text{kV}$  (contact)**  
**IEC 61000-4-4 (EFT) 40A (5/50ns)**
- ◆ Array of surge rated diodes with internal TVS Diode
- ◆ Small package (2.4 x 2.2mm) saves board space
- ◆ Protects up to four I/O lines & power line
- ◆ Low capacitance ( **$< 3\text{pF}$** ) for high-speed interfaces
- ◆ No insertion loss to **2.0GHz**
- ◆ Low leakage current and clamping voltage
- ◆ Low operating voltage: 5.0V
- ◆ Solid-state silicon-avalanche technology

#### Mechanical Characteristics

- ◆ EIAJ SC-70 6L package
- ◆ Lead Finish: Matte Tin
- ◆ RoHS/WEEE Compliant
- ◆ Molding compound flammability rating: UL 94V-0
- ◆ Marking : F54
- ◆ Packaging : Tape and Reel per EIA 481

#### Applications

- ◆ USB 2.0
- ◆ USB OTG
- ◆ Monitors and Flat Panel Displays
- ◆ Digital Visual Interface (DVI)
- ◆ High-Definition Multimedia Interface (HDMI)
- ◆ Gigabit Ethernet
- ◆ SIM Ports
- ◆ IEEE 1394 Firewire Ports

#### Circuit Diagram

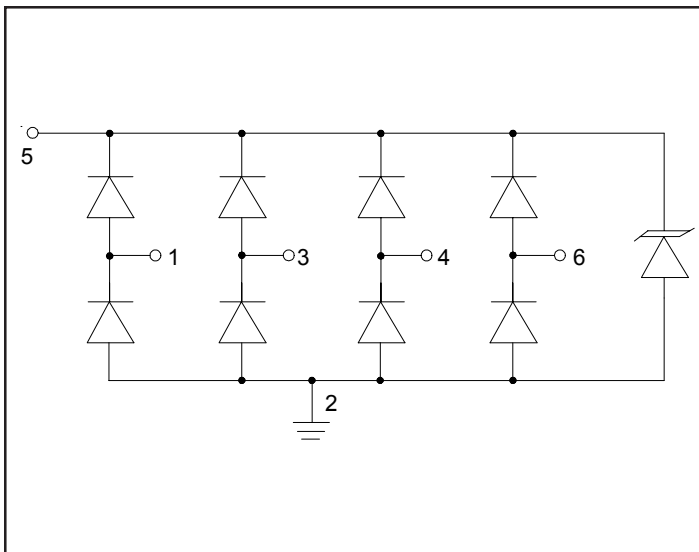

#### Schematic & PIN Configuration

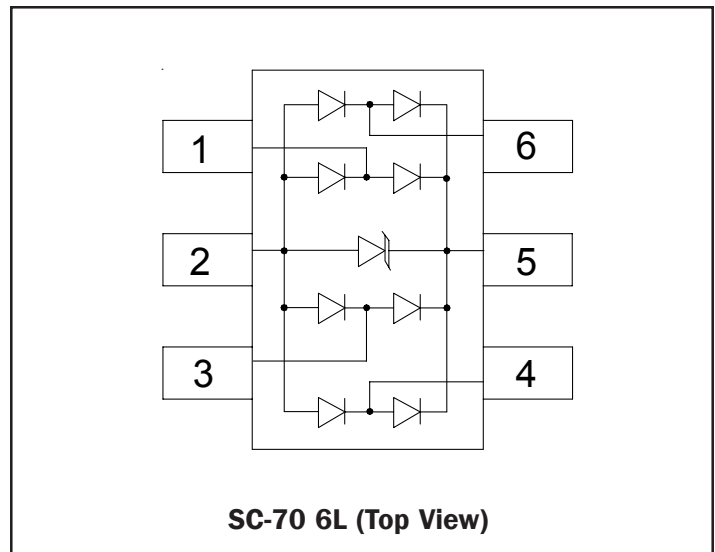

**PROTECTION PRODUCTS**
**Absolute Maximum Rating**

Rating	Symbol	Value	Units
Peak Pulse Power (tp = 8/20μs)	$P_{pk}$	150	Watts
Peak Pulse Current (tp = 8/20μs)	$I_{pp}$	6	A
ESD per IEC 61000-4-2 (Air) ESD per IEC 61000-4-2 (Contact)	$V_{ESD}$	15 8	kV
Operating Temperature	$T_J$	-55 to +125	°C
Storage Temperature	$T_{STG}$	-55 to +150	°C

**Electrical Characteristics (T=25°C)**

Parameter	Symbol	Conditions	Minimum	Typical	Maximum	Units
Reverse Stand-Off Voltage	$V_{RWM}$	Pin 5 to 2			5	V
Reverse Breakdown Voltage	$V_{BR}$	$I_t = 1mA$ Pin 5 to 2	6			V
Reverse Leakage Current	$I_R$	$V_{RWM} = 5V, T=25°C$ Pin 5 to 2			3	μA
Clamping Voltage	$V_C$	$I_{pp} = 1A, tp = 8/20μs$ Any pin to pin 2			15	V
Clamping Voltage	$V_C$	$I_{pp} = 6A, tp = 8/20μs$ Any pin to pin 2			25	V
Junction Capacitance	$C_J$	$V_R = 0V, f = 1MHz$ Any I/O pin to pin 2			3	pF
		$V_R = 0V, f = 1MHz$ Between I/O pins			1.5	pF

Note 1: I/O pins are pin 1, 3, 4, and 6

## PROTECTION PRODUCTS

### Typical Characteristics

#### Non-Repetitive Peak Pulse Power vs. Pulse Time

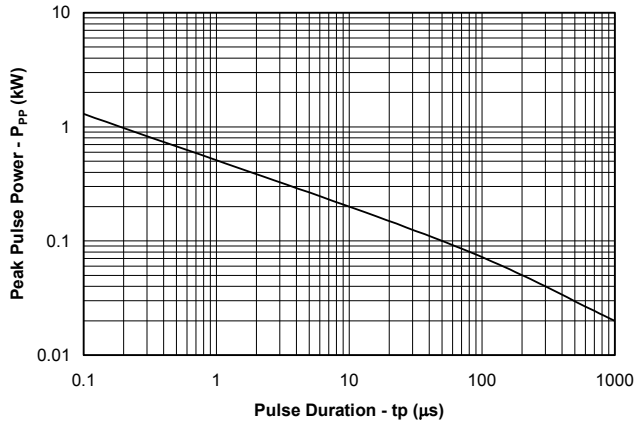

#### Power Derating Curve

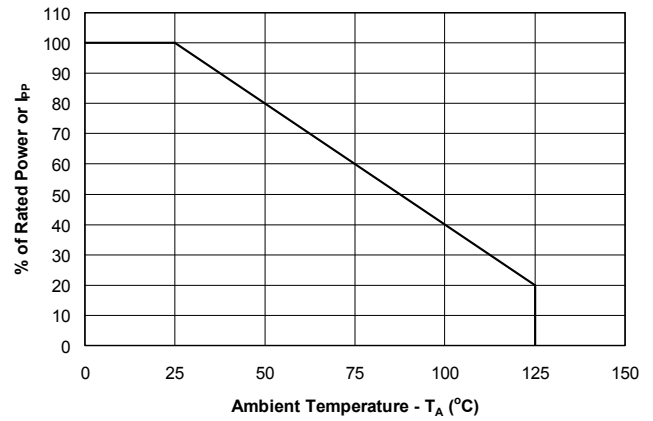

#### Pulse Waveform

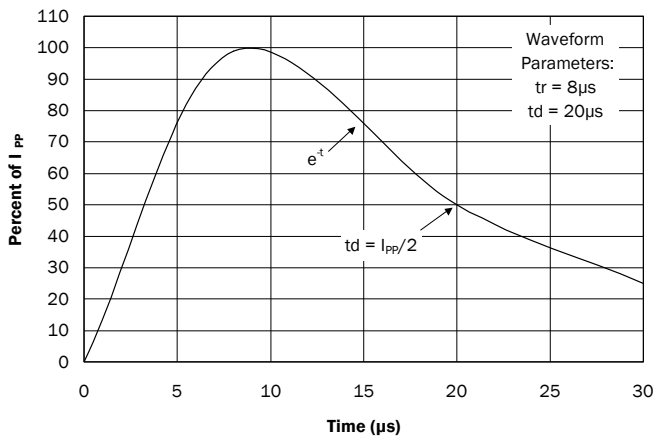

#### Clamping Voltage vs. Peak Pulse Current

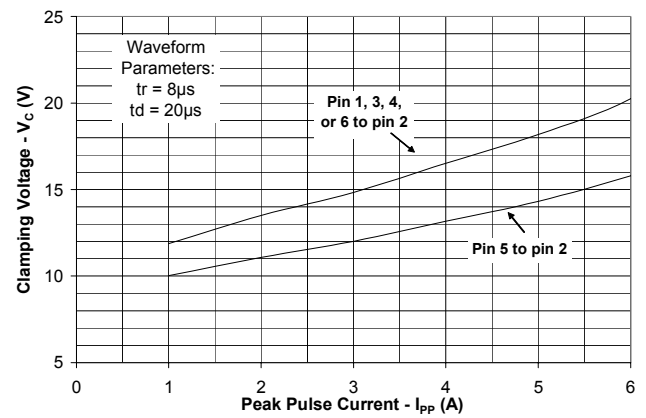

#### Forward Voltage vs. peak Pulse Current

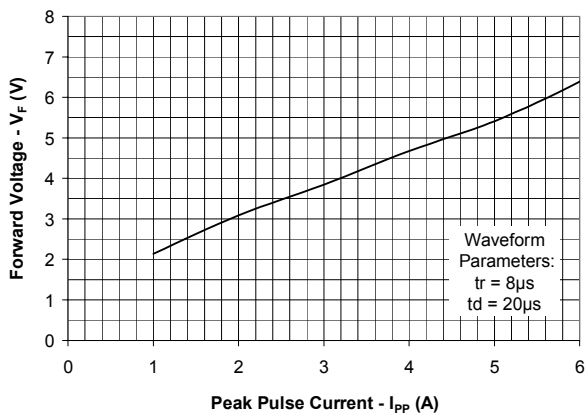

#### Capacitance vs. Reverse Voltage (Normalized to 0V)

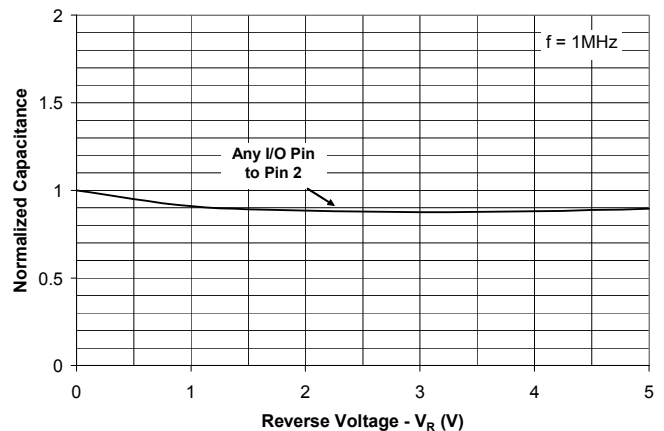

PROTECTION PRODUCTS

Typical Characteristics

Insertion Loss S21 (I/O to Pin 2)

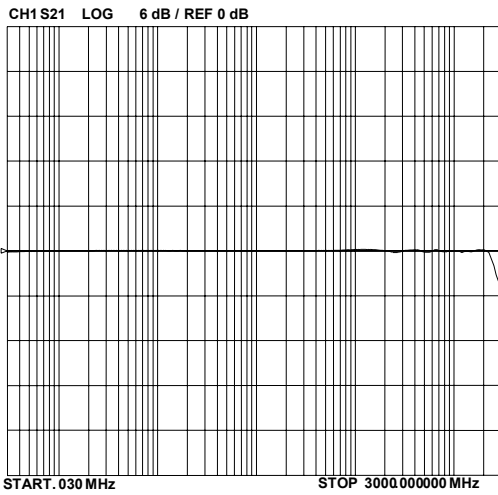

Insertion Loss S21 (I/O to I/O)

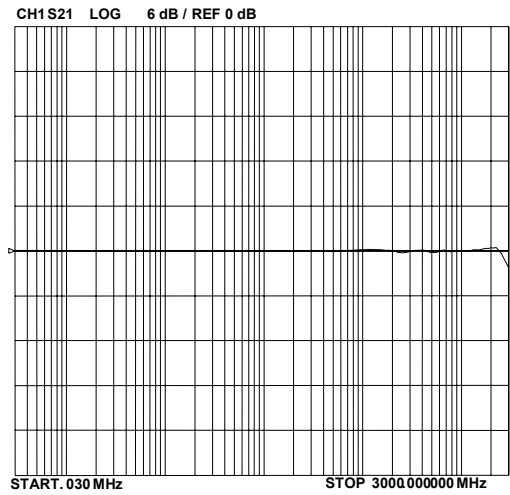

Analog Crosstalk

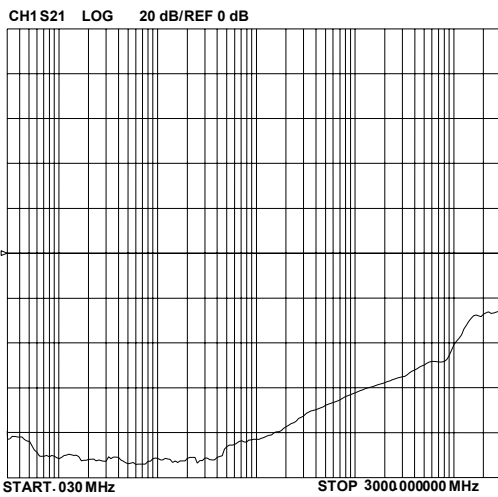

ESD Response (8kV Contact per IEC 61000-4-2)

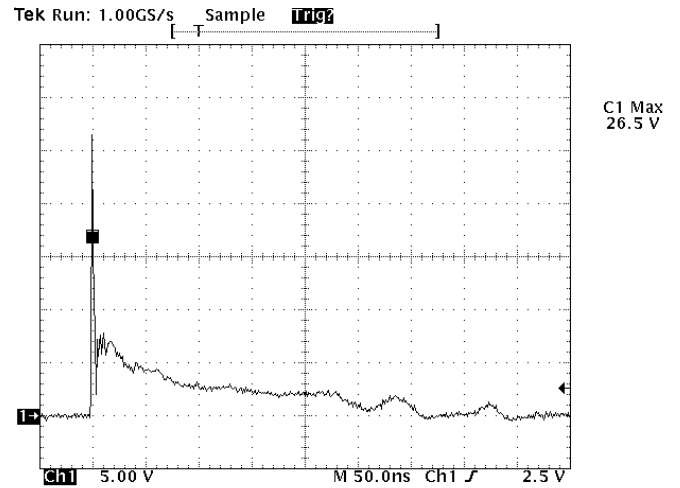

## PROTECTION PRODUCTS

### Applications Information

#### Device Connection Options for Protection of Four High-Speed Data Lines

This device is designed to protect data lines by clamping them to a fixed reference. When the voltage on the protected line exceeds the reference voltage the steering diodes are forward biased, conducting the transient current away from the sensitive circuitry. Data lines are connected at pins 1, 3, 4 and 6. Pin 2 should be connected directly to a ground plane. The path length is kept as short as possible to minimize parasitic inductance.

The positive reference is connected at pin 5. The options for connecting the positive reference are as follows:

1. To protect data lines and the power line, connect pin 5 directly to the positive supply rail ( $V_{CC}$ ). In this configuration the data lines are referenced to the supply voltage. The internal TVS diode prevents over-voltage on the supply rail.
2. In applications where the supply rail does not exit the system, the internal TVS may be used as the reference. In this case, pin 5 is not connected. The steering diodes will begin to conduct when the voltage on the protected line exceeds the working voltage of the TVS (plus one diode drop).
3. In applications where complete supply isolation is desired, the internal TVS is again used as the reference and  $V_{CC}$  is connected to one of the I/O inputs. An example of this configuration is the protection of a SIM port. The Clock, Reset, I/O, and VCC lines are connected at pins 1, 3, 4, and 6. Pin 2 is connected to ground and pin 5 is not connected.

#### Matte Tin Lead Finish

Matte tin has become the industry standard lead-free replacement for SnPb lead finishes. A matte tin finish is composed of 100% tin solder with large grains. Since the solder volume on the leads is small compared to the solder paste volume that is placed on the land pattern of the PCB, the reflow profile will be determined by the requirements of the solder paste. Therefore, these devices are compatible with both lead-free and SnPb assembly techniques. In addition, unlike other lead-free compositions, matte tin does not have any added alloys that can cause degradation of the solder joint.

#### Protection of Four Data Lines and Power Supply Line

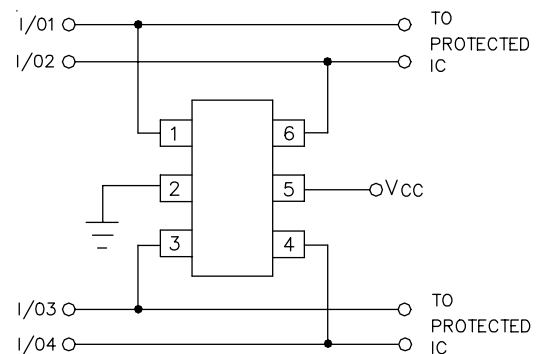

#### Protection of Four Data Lines Using Internal TVS Diode as Reference

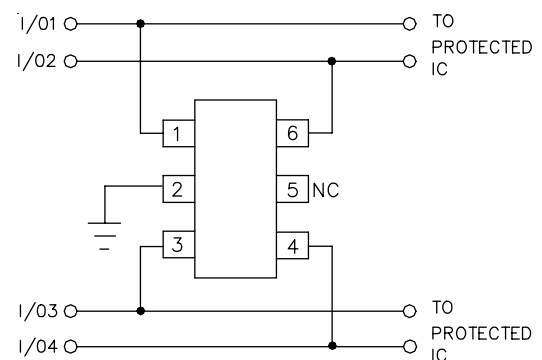

**PROTECTION PRODUCTS**

**Typical Applications**

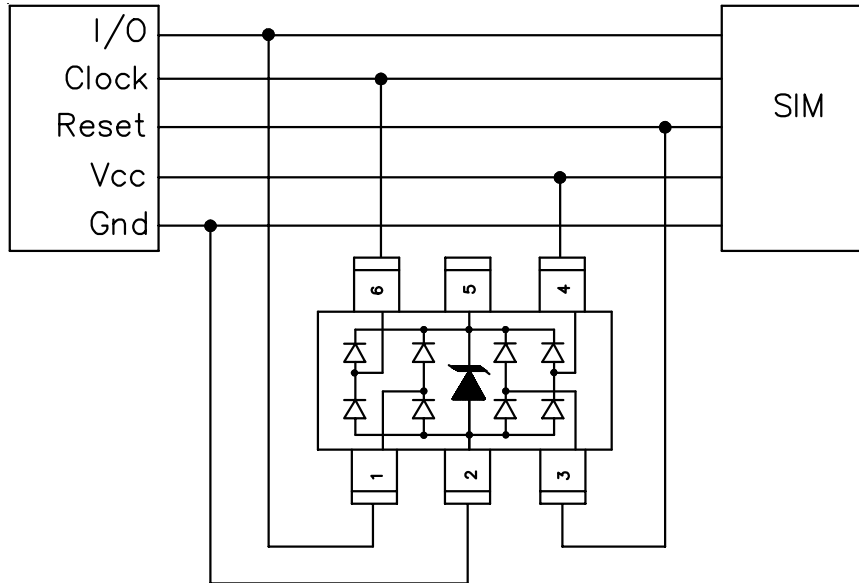

**SIM Port - Protection of Three Data Lines and VCC**

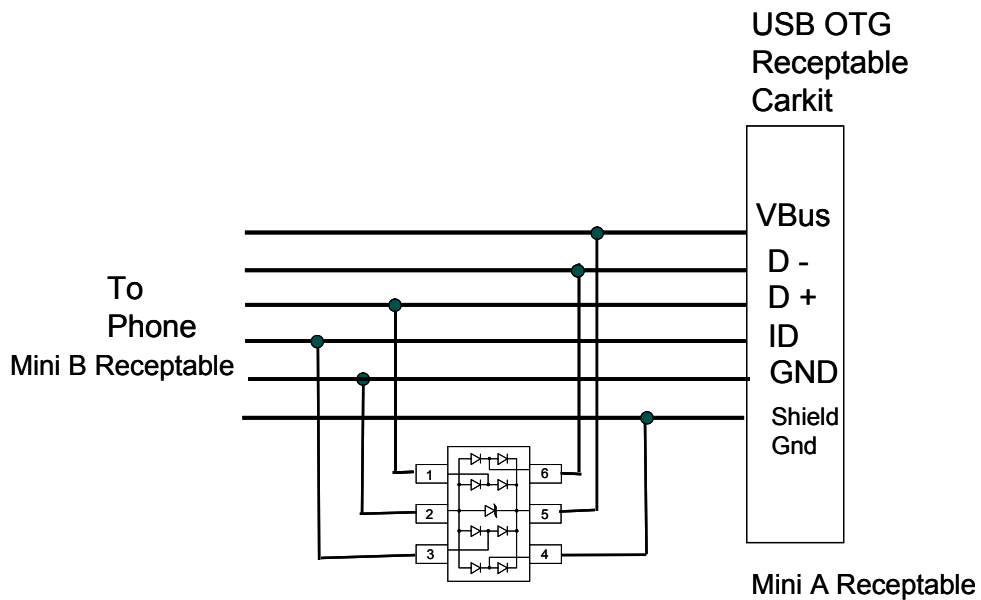

**USB OTG CarKit Protection**

## PROTECTION PRODUCTS

### Typical Applications

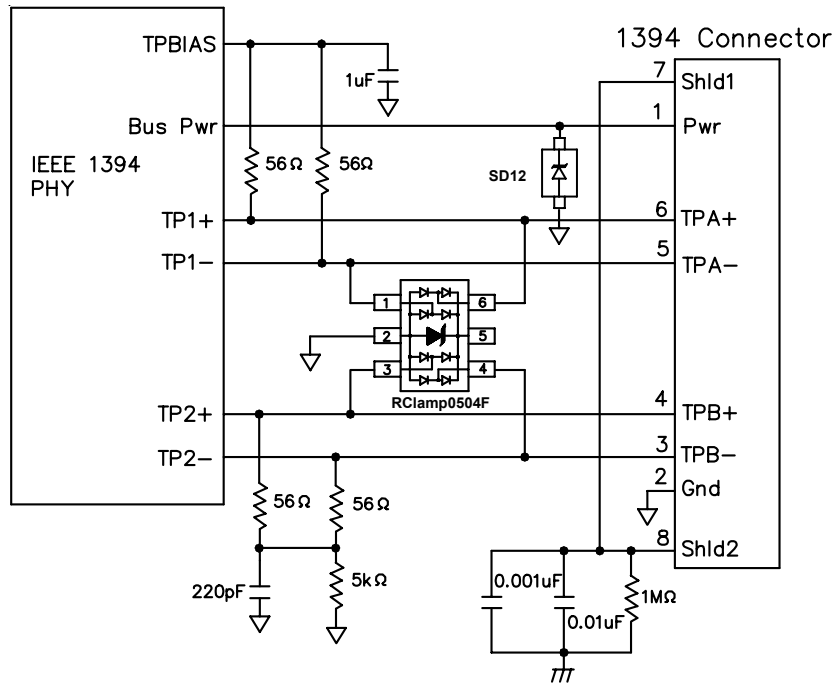

**IEEE 1394 Firewire Protection**

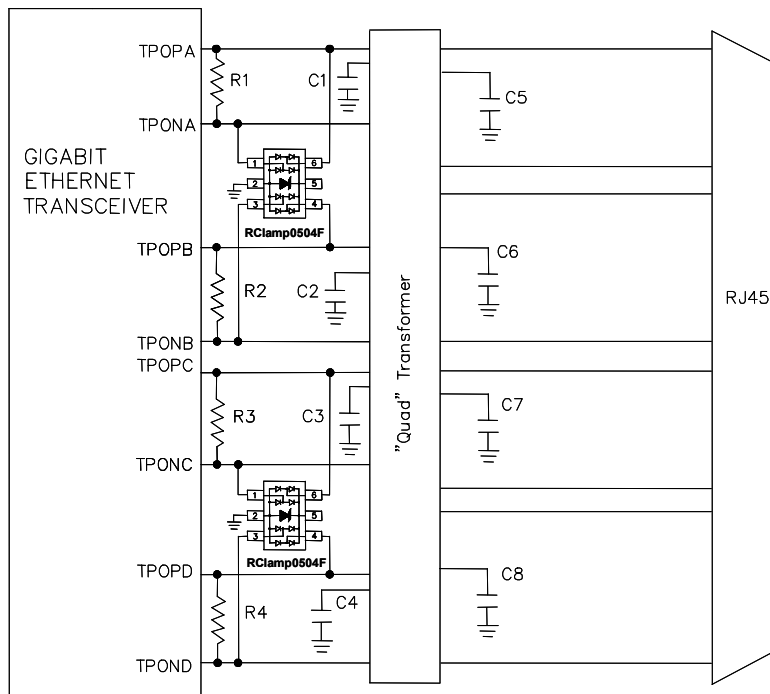

**Gigabit Ethernet Protection**

## PROTECTION PRODUCTS

### Outline Drawing - SC70-6L

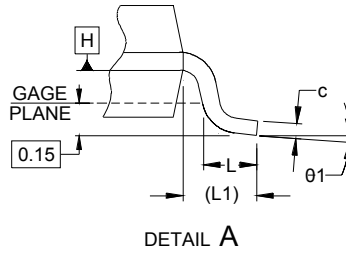
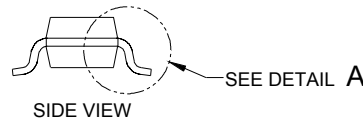
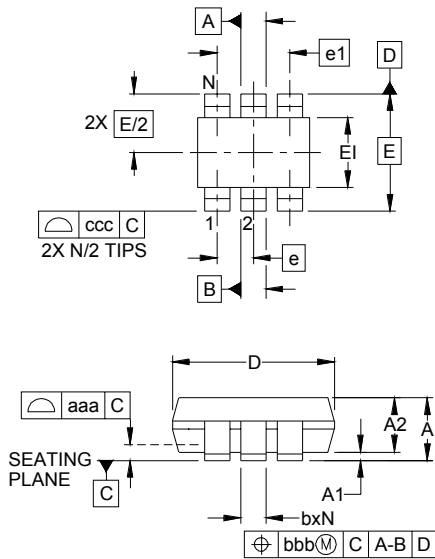

DIM	INCHES			MILLIMETERS		
	MIN	NOM	MAX	MIN	NOM	MAX
A	-	-	.043	-	-	1.10
A1	.000	-	.004	0.00	-	0.10
A2	.028	.035	.039	0.70	0.90	1.00
b	.006	-	.012	0.15	-	0.30
c	.003	-	.009	0.08	-	0.22
D	.075	.079	.083	1.90	2.00	2.10
E1	.045	.049	.053	1.15	1.25	1.35
E	.083 BSC			2.10 BSC		
e	.026 BSC			0.65 BSC		
e1	.051			1.30 BSC		
L	.010	.014	.018	0.26	0.36	0.46
L1	(0.017)			(0.42)		
N	6			6		
theta1	0°	-	8°	0°	-	8°
aaa	.004			0.10		
bbb	.004			0.10		
ccc	.012			0.30		

**NOTES:**

1. CONTROLLING DIMENSIONS ARE IN MILLIMETERS (ANGLES IN DEGREES).
2. DATUMS **-A-** AND **-B-** TO BE DETERMINED AT DATUM PLANE **-H-**
3. DIMENSIONS "E1" AND "D" DO NOT INCLUDE MOLD FLASH, PROTRUSIONS OR GATE BURRS.
4. REFERENCE JEDEC STD MO-203, VARIATION AB.

### Land Pattern - SC70-6L

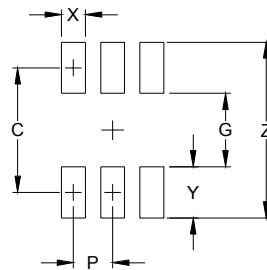

DIMENSIONS		
DIM	INCHES	MILLIMETERS
C	(.073)	(1.85)
G	.039	1.00
P	.026	0.65
X	.016	0.40
Y	.033	0.85
Z	.106	2.70

**NOTES:**

1. THIS LAND PATTERN IS FOR REFERENCE PURPOSES ONLY. CONSULT YOUR MANUFACTURING GROUP TO ENSURE YOUR COMPANY'S MANUFACTURING GUIDELINES ARE MET.



## PROTECTION PRODUCTS

### Marking

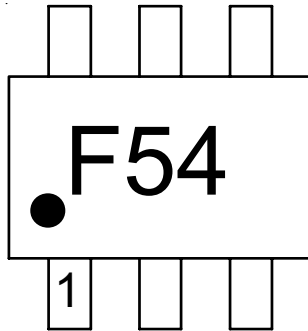

### Ordering Information

Part Number	Qty per Reel	Reel Size
RClamp0504F.TCT	3,000	7 Inch

RailClamp and RClamp are trademarks of Semtech Corporation

### Tape and Reel Specification

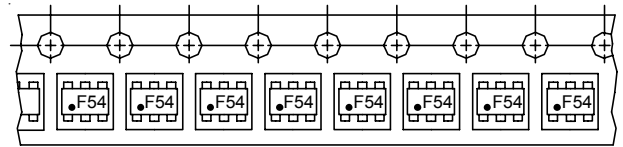
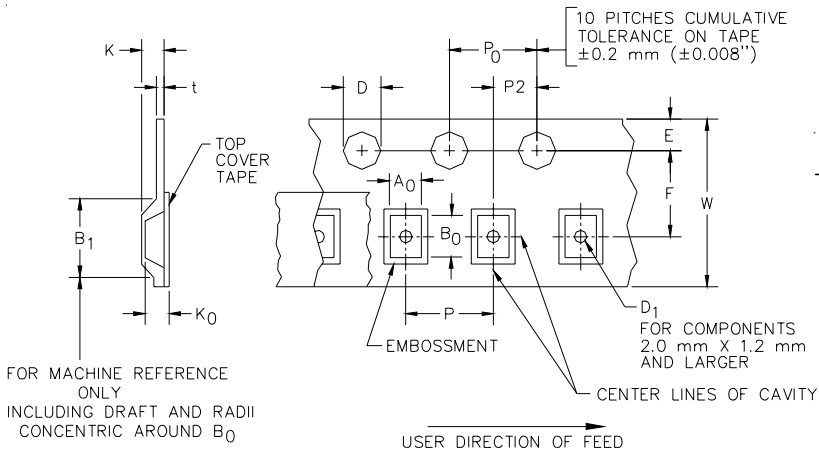

**Device Orientation in Tape**

Tape Width	B, (Max)	D	D1 (MIN)	E	F	K (MAX)	P	P0	P2	T(MAX)	W
8 mm	4.2 mm (.165)	1.5 + 0.1 mm - 0.0 mm (0.59 +.005 -.000)	1.0 mm (.039)	1.750±.10 mm (.069±.004)	3.5±0.05 mm (.138±.002)	2.4 mm (.094)	4.0±0.1 mm (.157±.00- 4)	4.0±0.1 mm (.157±.00- 4)	2.0±0.05m- m (.079±.002)	0.4 mm (.016)	8.3 mm (.312±.012)

### Contact Information

Semtech Corporation  
 Protection Products Division  
 200 Flynn Rd., Camarillo, CA 93012  
 Phone: (805)498-2111 FAX (805)498-3804